

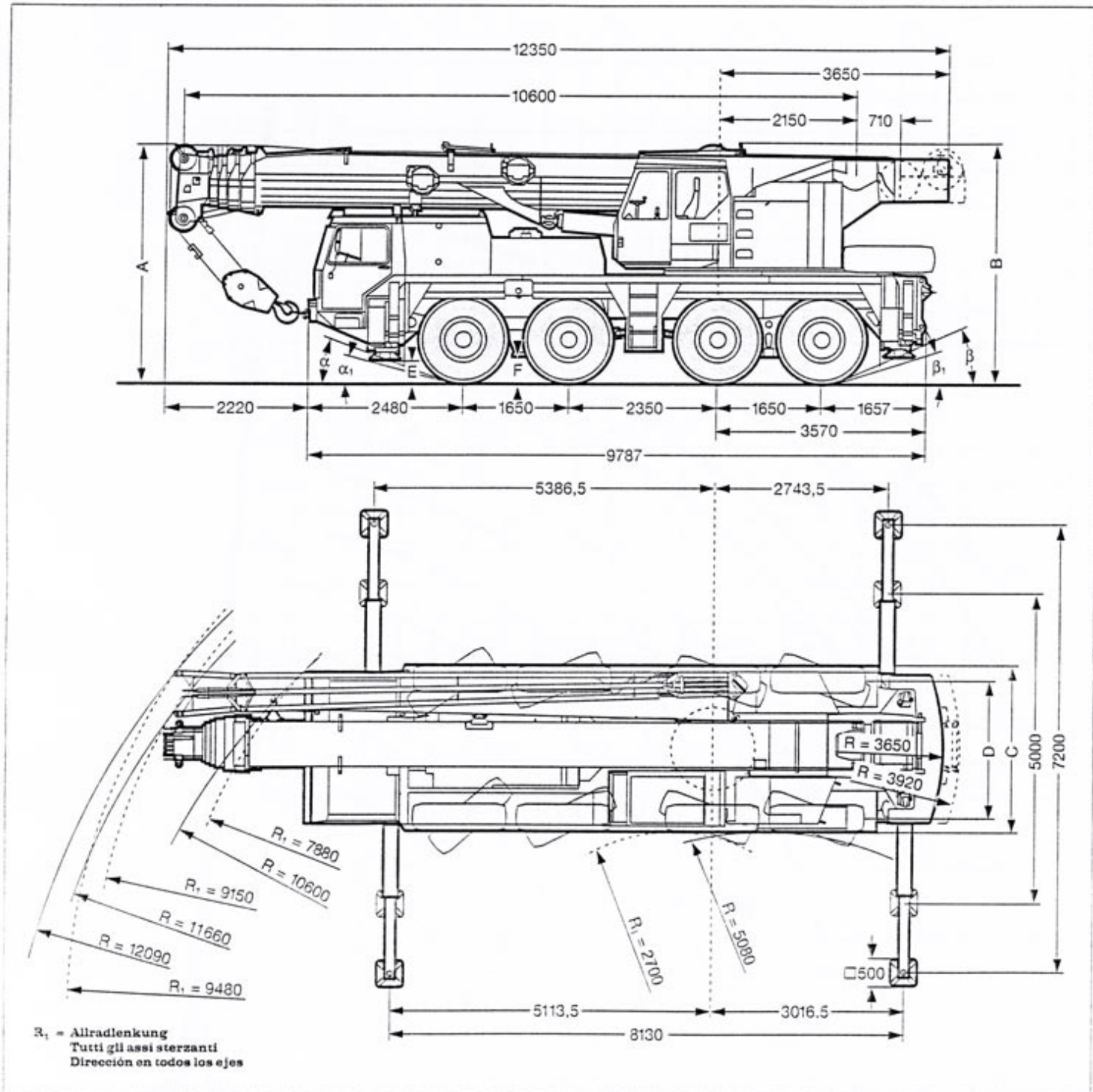

AUTOGRU - LTM 1070/1

DIMENSIONI



	Maße / Dimensioni / Dimensiones mm										
	A	A 100 mm*	B	C	D	E	F	α	α_1	β	β_1
14.00 R 25	3750	3650	3800	2500	2123	280	410	21°	15°	22°	18°
16.00 R 25	3800	3700	3850	2680	2235	330	460	23°	17°	24°	20°

* abgesenkt / abbassato / suspensión abajo



ALTEZZE DI SOLLEVAMENTO

